

FILLING MACHINE

TABLETOP GRAVITY FILLERS



APACKS FGT-4000-AP Tabletop Four Head Gravity Filler is ideal for a variety of thin products. Accuracies are achieved using the volumetric-by-time filling method.

The FGT-4000-AP is manufactured with a heavy duty 304 stainless steel, tig-welded frame and is available with Four 316 stainless steel Fill Heads. PLC Controls with touch screen HMI and a Polyethylene Gravity Reservoir come standard. Options are available for even more versatility.

Gravity Fillers are commonly used for filling beverages and other thin products, especially where foaming may be an issue.



Shown with integrated table and rails, sold separately.

SPECIFICATION

Standard Construction: 304SS tig-welded frame

Number of Fill Heads: 4

Filling Size: 1oz to 1gal with upgradable capability

Filling Speed: Dependent on operator & products

Power Requirement:

120V, single phase, 15 amp, 50-60Hz

Air Requirement: 2-5CFM @ 90PSI

clean, dry, compressed air

Dimensions & Weight:

• Length 26.17" (665mm)-

• Width - 29.58" (751mm)

- Height - 45.10" (1146mm)
- Weight - 200lbs for Filler only (90.72kg)

Standard Features:

- PLC Controls
- Stainless steel Filling Heads and Filling Nozzles (Nozzles purchased separately)
- Product Infeed Valve, air-actuated 316SS ball valve
- Polyethylene Gravity Reservoir (MDPE)
- Individual Fill Head adjustment
- Foot Pedal
- Cycle Selector Switch Foot Pedal or Auto Mode



Shown configured for corrosive products

FILLING MACHINE

TABLETOP GRAVITY FILLERS



OPTIONS

- 316SS or plastic wetted contact parts
- Product Supply Pump
- Modifications for large/miniature containers
- Custom applications
- Special electrical requirements
- Additional remote E-stops
- Sanitary, hazardous, flammable and corrosive environment construction

APPLICATIONS

- | | |
|----------------------|----------------------|
| Water | Essential Oils |
| Fruit Juices | Ink |
| Extracts | Thin Liquid Soap |
| Liquid Tea | Shampoo's |
| Liquid Coffee | Light Makeup remover |
| Food Coloring | Motor Oil |
| Vegetable Oil | Urethane |
| Milk | Silicone |
| Wine | Urine |
| Tomato juice | Alcohol |
| Some Salad Dressings | and many more |
| Perfumes | |

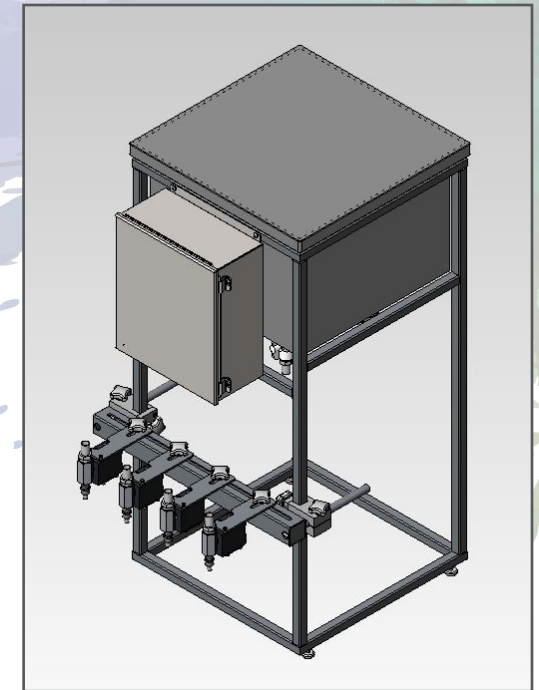
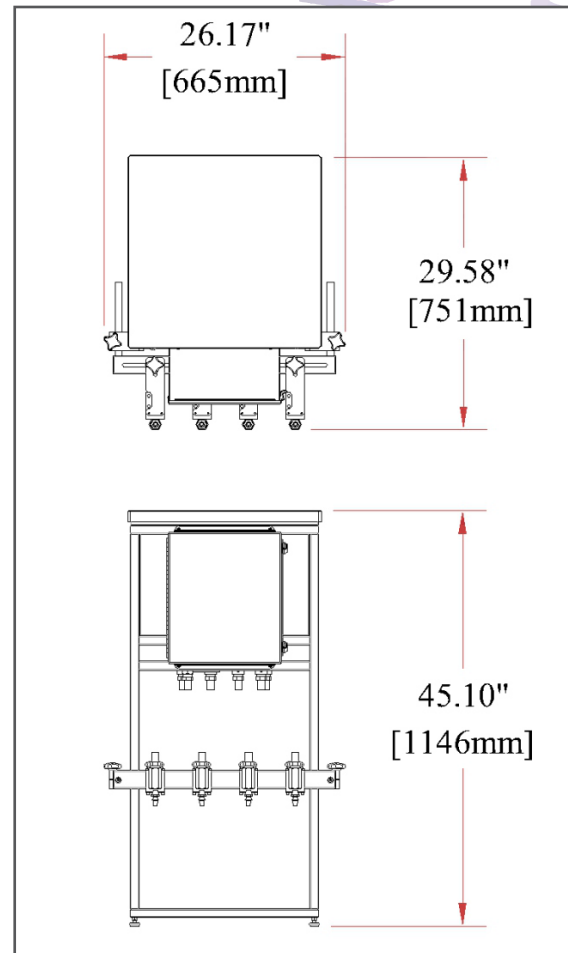

- **Complete line of filling and packaging solutions**
- **Standard filling machines in stock and ready to ship**
- **Economical prices, installation services and excellent customer service**

1500 Lake Street, La Porte, Indiana 46350
Local & Outside US: 219-369-4131
Toll Free: 866-369-9030
Fax: 574-975-2711

sales@apackas.com
www.apackas.com